

CRYOSTAT WITH QHR PROBE

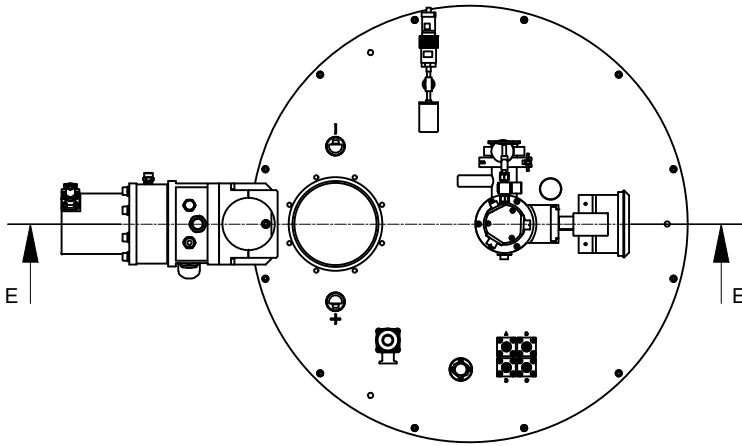

QHR PROBE IN AIRLOCK
C-C (1 : 13)

QHR PROBE AT FIELD CENTRE
E-E (1 : 13)

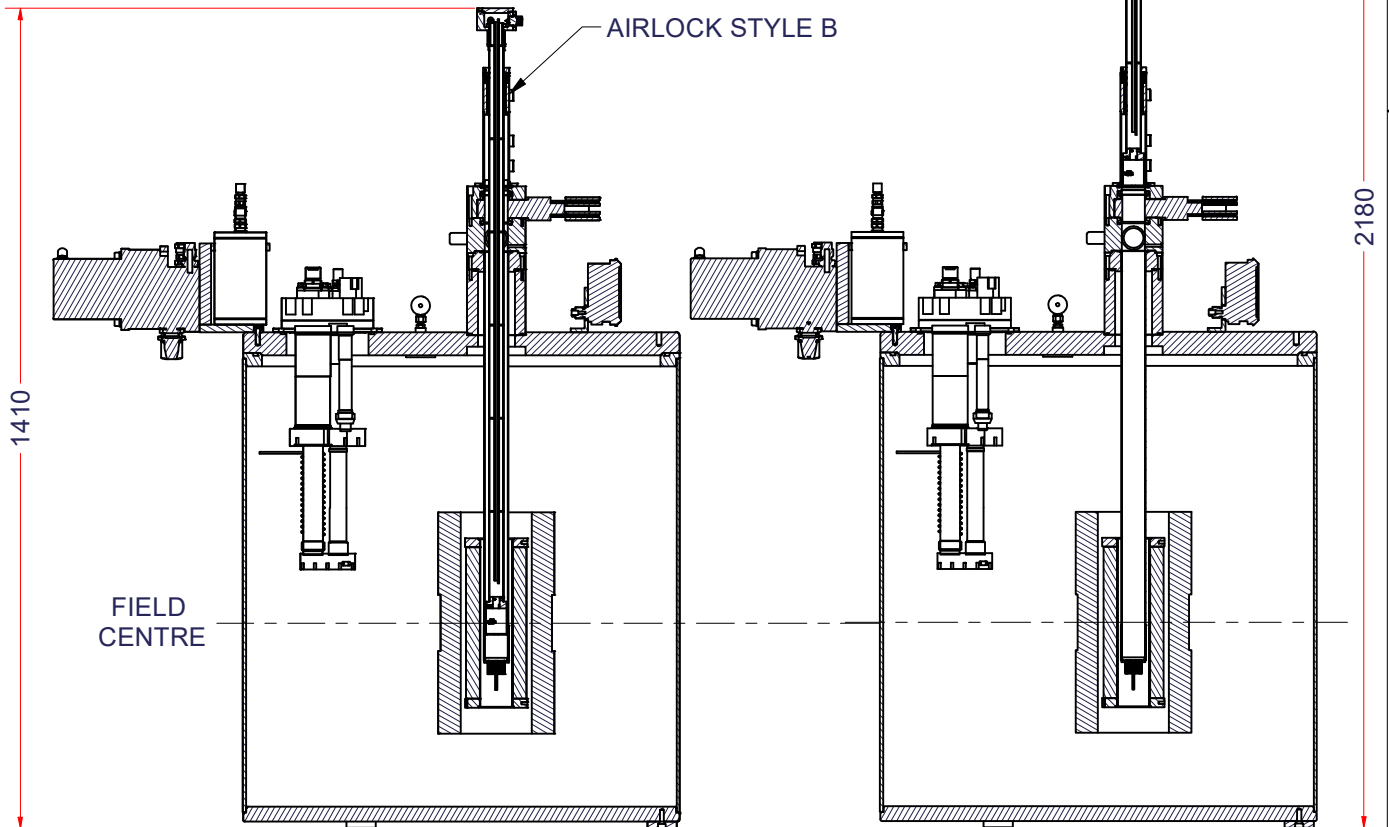

TOLERANCES (Unless stated) 0 = +/- 0.5 0.1 = +/- 0.1 0.01 = +/- 0.02 0.001 = +/- 0.001 ANGULAR = +/- 0.1° SURFACE FINISH = 3.2 µm BREAK ALL SHARP EDGES DO NOT SCALE	DWG No.		CRYOGENIC LTD MATERIAL SPECIFICATION CUSTOM FINISH		
	SHEET 1 OF 1				FIRST DRAFT:
	STD.PART No.		THIS DRAFT:		
	THIRD ANGLE PROJECTION				
THIS DRAWING BELONGS TO CRYOGENIC LTD AND IS ISSUED ON THE CONDITION THAT IT IS NOT COPIED, REPRINTED OR DISCLOSED EITHER IN WHOLE OR IN PART TO A THIRD PARTY WITHOUT THE PRIOR CONSENT OF: CRYOGENIC LTD, ACTON PARK IND. ESTATE, THE VALE, LONDON W3 7QE			DIMENSION	REVISION LETTER	JOB NUMBER
			DRAWN BY:	REVIEWED BY:	QUANTITY